



Original article

<https://doi.org/10.21285/1814-3520-2022-3-508-518>

Development of measures to reduce grid energy losses in the Namangan Region of Uzbekistan

Stepan G. Tiguntsev^{1✉}, Sardor B. Akhmedov², Said B. Usmonov³

^{1,3}Irkutsk National Research Technical University, Irkutsk, Russia

²Melentiev Energy Systems Institute SB RAS, Irkutsk, Russia

¹tsg@istu.edu; stiguncev@yandex.ru, orcid.org/0000-0003-1525-0937

²sarik0696@gmail.com

³saidchik2697@gmail.com

Abstract. The paper is aimed at developing technical and organizational measures to reduce the losses of electrical energy during its transmission via main and distribution electrical grids, in power transformers and electric power transmission lines. The focus of the study was on electrical grid modes in the Namangan Region of Uzbekistan (voltages of 220/110/35/10/6 kV), which were analyzed via technological calculation-based research methods using an equivalent circuit representing the linear circuit currently employed in the regional electric energy system. In addition, electrical grids were simulated using the software package “Program for calculating electrical grid modes” followed by the processing of calculation results by means of the Microsoft Excel package. The paper calculates electrical modes for the equivalent circuit of the regional electric energy system, as well as offering technical measures (installation of reactive power compensation devices; adjustment of transformation ratios in power transformers) aimed at adjusting voltage to improve electric power quality in terms of voltage deviations and lower power losses. Voltage deviations in most grid nodes were found to be inconsistent with GOST 32144-2013. Thus, in 35 kV, 10 kV, and 6 kV nodes, the largest underdeviation amounted to 12.45 kV, 3.26 kV, and 2.09 kV, respectively. For the placement of reactive power compensating devices having a total power of 67.82 MV·Ar, 35 kV nodes were used; in addition, the values of transformer ratios at transformer substations (35–110 kV) were determined. Calculations indicate that the conducted activities can normalize voltage in the 35 kV, 10 kV, and 6 kV nodes while reducing power losses in the electrical grid by 9.35 MW. It is estimated that the proposed measures will be paid back in approximately three years. By means of compensating reactive power and adjusting transformer ratios, these measures can reduce electrical energy losses during transmission in the considered objects and maintain a given voltage level.

Keywords: electric power quality, electrical energy losses, voltage deviation, grid mode, electrical equipment, transformer ratio

For citation: Tiguntsev S. G., Akhmedov S. B., Usmonov S. B. Development of measures to reduce grid energy losses in the Namangan Region of Uzbekistan. *iPolytech Journal*. 2022;26(3):508-518. <https://doi.org/10.21285/1814-3520-2022-3-508-518>.

ЭНЕРГЕТИКА

Научная статья

УДК 621.316.722.076.12

Разработка мероприятий по снижению потерь электроэнергии в электрических сетях Наманганской области Республики Узбекистан

Степан Георгиевич Тигунцев^{1✉}, Сардор Бахтиярович Ахмедов²,
Саид Бахтиярович Усмонов³

^{1,3}Иркутский национальный исследовательский технический университет, г. Иркутск, Россия

²Институт систем энергетики им. Л.А. Мелентьева СО РАН, Иркутск, Россия

¹tsg@istu.edu; stiguncev@yandex.ru, orcid.org/0000-0003-1525-0937

© Tiguntsev S. G., Akhmedov S. B., Usmonov S. B., 2022

²sarik0696@gmail.com

³saidchik2697@gmail.com

Резюме. Цель – разработка организационно-технических мероприятий по сокращению потерь электроэнергии при ее транспортировке в магистральных и распределительных электрических сетях, в силовых трансформаторах и линиях электропередачи. Объектом исследований явились режимы работы электрической сети Наманганской области Республики Узбекистан напряжением 220/110/35/10/6 кВ. Использовались технологические методы исследования расчетным путем по схеме замещения действующей линейной схемы электроэнергетической системы области. Также использовалось моделирование электрических сетей с помощью программного комплекса «Программа расчета режимов электрических сетей» и обработка результатов расчетов с помощью пакета Microsoft Excel. В результате исследований рассчитаны электрические режимы схемы замещения электроэнергетической системы области, предложены технические мероприятия (установка устройств компенсации реактивной мощности и регулирование коэффициентов трансформации силовых трансформаторов) по регулированию напряжения для повышения качества электроэнергии в части отклонения напряжений и снижению потерь мощности. Установлено, что отклонения напряжений в большинстве узлов сети не соответствуют ГОСТ 32144-2013. Так, в узлах с напряжением 35 кВ наибольшее отрицательное отклонение напряжений составило 12,45 кВ, на 10 кВ – 3,26 кВ, на 6 кВ – 2,09 кВ. Определены узлы сети на стороне 35 кВ для размещения устройств компенсации реактивной мощности, суммарное значение мощностей составило 67,82 МВ·Ар; также определены величины коэффициентов трансформации на трансформаторных подстанциях, находящихся в диапазоне 35–110 кВ. Расчетами показано, что проведенные мероприятия позволяют увеличить напряжение в узлах 35, 10, 6 кВ до нормы, а также снизить потери мощности в сети на 9,35 МВт. Установлено, что расчетная окупаемость предложенных мероприятий составит ~ 3 года. Предлагаемые мероприятия позволяют сократить потери электроэнергии при ее транспортировке в изученных объектах и поддерживать напряжения на заданном уровне за счет компенсации реактивной мощности и регулирования коэффициентов трансформации.

Ключевые слова: качество электроэнергии, потери электроэнергии, отклонение напряжения, режим электрической сети, электрооборудование, коэффициент трансформации

Для цитирования: Тигунцев С. Г., Ахмедов С. Б., Усмонов С. Б. Разработка мероприятий по снижению потерь электроэнергии в электрических сетях Наманганской области Республики Узбекистан // iPolytech Journal. 2022. Т. 26. № 3. С. 508–518. (In Eng.). <https://doi.org/10.21285/1814-3520-2022-3-508-518>.

INTRODUCTION

Electrical energy losses can be divided into technical and commercial losses. Since technical losses are directly related to electric power quality, it is necessary to develop methods for assessing electrical energy losses depending on the deviation of indicators characterizing electric power quality from the normalized values.

Since electric power quality has a significant effect on the operating conditions for both the electrical grid of companies and process equipment, the provision of electric power quality is the second most important task undertaken by power suppliers [1, 2].

The deviations of indicators reflecting electric power quality from the normalized values characterize the operating conditions for the electrical equipment of power suppliers and consumers, as well as possible damages both in the industrial and residential sectors.

The most common types of current-using equipment, widely used in various industries, include electric motors and electric lighting systems. Electrothermal systems, as well as valve converters, are also becoming increasingly widespread. Electric motors are used in the drives of various machinery. Systems that do not require rotational speed control during operation use asynchronous and synchronous motors⁴ [3].

Voltage deviation. Gradual changes in the supply voltage (usually lasting at least 1 minute) are typically associated with changes in the electrical grid load.

Electric power quality indicators reflecting slow changes in supply voltage include the under- $\delta U_{(-)}$ and over- $\delta U_{(+)}$ deviations of supply voltage from the nominal/matched value (%) at a given point of an electrical system:

⁴Electricity, equipment. Available from: <https://forca.com.ua> [Accessed 25th February 2022] / Электроэнергетика, обладнання [Электронный ресурс]. URL: <https://forca.com.ua> (25.02.2022).

$$\delta U_{(-)} = [(U_0 - U_{m(-)}) / U_0] \cdot 100,$$

$$\delta U_{(+)} = [(U_{m(+)} - U_0) / U_0] \cdot 100,$$

where $U_{m(-)}, U_{m(+)}$ – values of supply voltage, V, lower than U_0 and higher than U_0 , respectively, averaged over a time interval of 10 min according to subsection 5.12. of GOST 30804.4.30⁵ [4–19]; U_0 – voltage equal to the standard nominal value U_{nom} or declared voltage U_c , V.

In low-voltage electrical grids, the standard nominal supply voltage U_{nom} amounts to 220 V (between phase and neutral conductors for single-phase and four-wire three-phase systems) and 380 V (between phase conductors for three- and four-wire three-phase systems).

In medium- and high-voltage electrical grids, declared supply voltage U_c is adopted instead of the nominal supply voltage.

The following norms are set for the above-mentioned indicators characterizing electric power quality: over- and underdeviations at a given point of an electrical system should not exceed 10% of the nominal or declared voltage value during a one-week period [19].

Effect of voltage deviations on the operation of an electrical grid and equipment. Load losses of power and electrical energy in power transformers and transmission lines are proportional to the square of the current and inversely proportional to the square of the voltage, while no-load losses determined according to the expression for total power losses with voltage deviations are proportional to the square of the voltage [5, 6]:

$$\Delta P = \Delta P_{L.nom} \cdot \left(\frac{100}{100 + \delta U}\right)^2 + \Delta P_{NL.nom} \cdot \left(\frac{100}{100 + \delta U}\right)^2,$$

where $\Delta P_{L.nom}, \Delta P_{NL.nom}$ – load and no-load power losses calculated at the nominal voltage, kW; δU – voltage deviation from the nominal value, %.

The increase (decrease) in power losses as compared to the nominal value is determined as follows [5]:

$$\delta P = \frac{\delta U}{50} \cdot (\Delta P_{NL.nom} - \Delta P_{L.nom}),$$

where δP – change in power losses, kW.

Provided that $\Delta P_{NL.nom} > \Delta P_{L.nom}$ in the grid, it makes sense to reduce voltage, as at $\delta U < 0$ the total losses will be ($\delta P < 0$) [5].

According to the level of electrical energy losses, it is possible to derive conclusions about the necessity and implementation scope of energy conservation measures.

Rising grid energy losses are attributed to objective trends in the general development of the power industry. The main trends include a continuous increase in electrical grid loads associated with the natural rise in consumer loads and the lower increase rate of the power transfer capability as compared to the electricity consumption increase rate⁶ [7].

A reduction of grid energy losses constitutes a complex problem that, among other things, requires personnel training and significant capital investments essential for optimizing the development of electrical grids, improving the electrical metering systems, introducing new information technologies in power supply activities, and managing grid modes⁷ [8].

⁵GOST 30804.4.30. Electric energy. Electromagnetic compatibility of technical equipment. Power quality measurement methods. Moscow: Standartinform; 2014. / ГОСТ 30804.4.30. Электрическая энергия. Совместимость технических средств электромагнитная. Методы измерений показателей качества электрической энергии. М.: Изд-во «Стандартинформ», 2014.

⁶On approval of the Regulations on the Ministry of Industry and Energy of the Russian Federation. Decree No. 284 of June 16, 2004. / Об утверждении Положения о Министерстве промышленности и энергетики Российской Федерации. Постановление № 284 от 16.06.2004.

⁷Vorotnickij V. E, Zaslouov S. V., Kalinkina M. A. Calculation, normalizing and reduction of electrical power losses when transmitted through electrical networks: textbook. Moscow; 2006. / Воротницкий В. Э., Заслонов С. В., Калинкина М. А. Расчет, нормирование и снижение потерь электроэнергии при ее передаче по электрическим сетям: учеб.-метод. пособ. М., 2006 г.

Due to the complexity of loss calculations and the presence of significant errors, special attention has recently been paid to the development of procedures for normalizing electrical energy losses.

The technical electrical energy losses include relatively constant and load (variable) electrical energy losses. Relatively constant losses constitute a part of technical losses in electrical grids that does not depend on the transmitted power. Load losses are losses in lines, power transformers, and current-limiting reactors depending on the transmitted load. The normalization of electrical energy losses is aimed at reducing losses or maintaining them at a technically and economically reasonable level [8].

The nominal voltage and active power are typically specified for a grid element in the considered load mode. The amount of voltage loss in a given grid element can be altered by changing its resistance and inductive reactance or reactive power transmitted through it.

Changes in the amount of transmitted reactive power affect voltage levels. Reactive power can be produced by power plant generators, as well as other reactive power sources, i.e., com-

pensating devices (CDs) and transmission lines. By regulating the amount of reactive power generated by different sources, it is possible to adjust the grid load in the section between them and the consequent amount of voltage losses in that grid section⁸ [11].

When developing grid development circuits, the reactive power shortage is ascertained at the stage of determining the balance between active and reactive power in distribution nodes for the calculation period. According to the calculation data, issues related to the required number of reactive power CDs, as well as their placement points, are addressed in the circuit. It is a priority to place CDs close to the consumer since this factor significantly affects grid energy losses and its quality at the consumer⁹ [12].

Two-winding and three-winding transformers, as well as autotransformers, can be installed at various points in electrical grids to increase or decrease grid voltage. The voltage mode at transformer installation points is typically unknown in advance; moreover, it may vary due to changes in energy consumption modes or grid parameters [13].

In order to effectively adjust voltage so as to maintain the required voltage levels (as per

⁸Ananicheva S. S., Alekseev A. A., Myzin A. L. Electrical power quality. Regulation of voltage and frequency in power systems: learning aids. Ekaterinburg; 2012, 93 p. / Ананичева С. С., Алексеев А. А., Мызин А. Л. Качество электроэнергии. Регулирование напряжения и частоты в энергосистемах: учеб.-метод. пособ. Екатеринбург, 2012. 93 с.

⁹Neklepaev B. N. Electrical part of power stations and substations: learning aids. Irkutsk, 1986. 640 p. / Неклепаев Б. Н. Электрическая часть электростанций и подстанций: учеб.-метод. пособ. Иркутск, 1986. 640 с.

¹⁰Strategy of energy efficiency improvement in municipalities. Available from: <https://pandia.ru/text/78/270/67411.php>. [Accessed 27th February 2022] / Стратегия повышения энергоэффективности в муниципальных образованиях [Электронный ресурс]. URL: <https://pandia.ru/text/78/270/67411.php>. (27.02.2022).

¹¹Akishin L. A., Prokopchuk K. I., Starostina E. B., Snopkova N. Yu. Electric power systems and networks: methodological guidelines for practice and course design. Irkutsk: Irkutsk National Research Technical University; 2015, 80 p. / Акишин Л. А., Прокопчук К. И., Старостина Э. Б., Снопкова Н. Ю. Электроэнергетические системы и сети: метод. указания для практ. занятий и курсового проектирования. Иркутск: Изд-во ИРНИТУ, 2015. 80 с.

¹²Idel'chik V. I. Electrical power systems and networks: a textbook for universities. Moscow: Izdatel'skij dom Al'yans; 2009, 592 p. / Идельчик В. И. Электрические системы и сети: учебник для вузов. М.: ООО «Издательский дом Альянс», 2009. 592 с.

¹³Fajbisovich D. L. Handbook on electrical network design. Moscow: Innovation Center ENAS; 2009, 392p. / Файбисович Д. Л. Справочник по проектированию электрических сетей. М.: НЦ «ЭНАС», 2009. 392 с.

¹⁴Neklepaev B. N., Kryuchkov I. P. Electrical part of power stations and substations. Reference materials for course and diploma designing: textbook for universities. 4th edition, revised. Moscow: Energoatomizdat; 1989, 608 p. / Неклепаев Б. Н., Крючков И. П. Электрическая часть электростанций и подстанций. Справочные материалы для курсового и дипломного проектирования: учеб. пособ. для вузов. 4-е изд., перераб. и доп. М.: Изд-во «Энергоатомиздат», 1989. 608 с.

¹⁵Rozhkova L. D., Kozulin V. S. Electrical equipment for stations and substations: a textbook for engineering vocational schools. Moscow: Energoatomizdat; 1987, 648 p. / Рожкова Л. Д., Козулин В. С. Электрооборудование для станций и подстанций: учебник для техникумов. М.: Изд-во «Энергоатомиздат», 1987. 648 с.

GOST 32144-2013¹⁶) at consumer buses and ensure energy-saving grid modes, it is necessary to modify transformer ratios. Therefore, step-down transformers and autotransformers are produced to allow for a 10–20% variation of the transformer ratio. If the highest nominal voltage does not exceed 220 kV, taps are typically on the supply side, i.e., on the high-voltage side in step-down transformers. At higher nominal voltages, grids are equipped with autotransformers featuring either mid-taps or those placed at the neutral point of common winding¹⁰⁻¹⁶ [12].

At the main substations, voltage should be adjusted via the counterload voltage control. In the case of extended feeders, it is used to reduce electrical energy losses and ensure an appropriate voltage level; self-regulating capacitor banks or voltage boosters should be installed as voltage regulators [13].

The paper examines the 220/110/35/10/6 kV electrical grid in the Namangan Region of Uzbekistan, calculates operating modes, as well as proposing technical measures aimed at adjusting voltage so as to improve electric power quality in terms of voltage deviation and lower power losses. The cost of the proposed measures was estimated. The studies involved calculations according to the linear circuit currently employed in the regional electric energy system. In order to simplify the calculations, a part of the circuit was selected. Fig. 1 shows a simplified electrical circuit of the Namangan Region.

An equivalent circuit was designed to calculate the modes. For each element (transformer, line, reactor, and substation buses), resistance and reactance, as well as the capacitive susceptance of transmission lines, were calculated¹⁰⁻¹⁴ [14–23]. For system transformers and autotransformers, resistance, reactance, transformer ratios, conductance, and shunt susceptance were determined.

In the grid, 6–10 kV electricity consumers were taken into account. Load values were obtained from the results of control measurements performed in 2016.

The initial data were entered into the PRRS computing system for calculating electrical grid modes developed at the Irkutsk National Research Technical University. The number of all nodes amounted to 461. For convenience, the nodes were numbered according to their voltage: for example, nodes numbered from 2000 – 220 kV, from 1000 – 110 kV, from 3000 – 35 kV, from 4100 – 10 kV, and from 4600 – 6 kV. The equivalent circuit parameters were entered in “Data: Nodes” and “Data: Connections.”

Fig. 3 shows a graph representing the voltage level of 35/10/6 kV nodes. It can be seen from the graphs that voltage deviations are inconsistent with GOST 32144-2013¹⁶, varying across a wide range. Thus, in the 35 kV, 10 kV, and 6 kV nodes, the largest voltage deviation amounted to 12.45 kV (3105 Galaba node), 3.26 kV (4142 Gova node), and 2.09 kV (4626 Yangier node), respectively.

With the mode calculation results in mind, it is proposed to select CD placement points and reduce transformer ratios by 10% at 110–35 kV transformer substations in order to reduce voltage deviations.

It is assumed that the proposed measures can increase voltage in the 110/35/10/6 kV nodes, as well as reducing grid power losses.

The studies revealed that the best CD placement points are the 35 kV nodes. The calculations yielded the following CD power values in the 35 kV nodes (see table).

It can be seen in fig. 3 a and 3 b that the implemented measures allow the transformer ratio K_t to be reduced by 10%, while the installation of CDs enabled a voltage normalization in the 35 kV, 10 kV, and 6 kV nodes, as well as reducing the grid power losses by 9.35 MW, which is determined as the difference between active power losses in the grid elements prior to (see fig. 2 a) and following (see fig. 2 b) the CD installation.

ECONOMIC INDICATORS

For CD installation, 35 kV nodes with selected placement points were used. Thirteen CDs

¹⁶GOST 32144-2013. Electrical Energy. Electromagnetic compatibility of engineering equipment. Standards for the quality of electrical energy in general-purpose power supply systems. Moscow: Standartinform; 2014. / ГОСТ 32144-2013. Электрическая энергия. Совместимость технических средств электромагнитная. Нормы качества электрической энергии в системах электроснабжения общего назначения. М.: Изд-во «Стандартинформ», 2014.

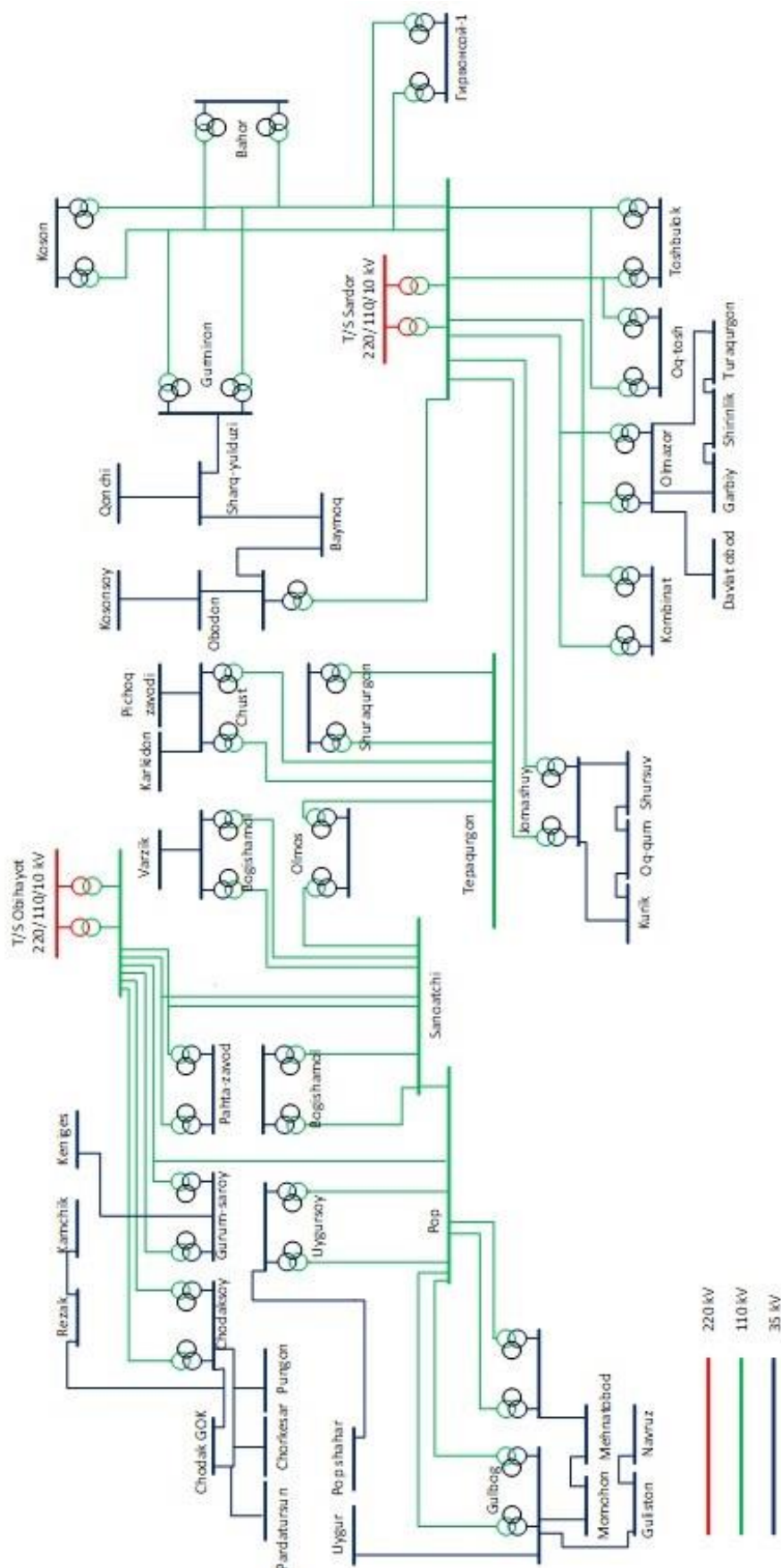

Fig. 1. Simplified linear circuit of the electrical grid in the Namangan Region
Рис. 1. Упрощенная линейная схема электрической сети Наманганской области

результат: схема			
количество подсистем	1		
отключено связей	0		
погашено узлов	0		
суммарные: (мвт)/(мгвар)	активные	реактивные	
выработка на станциях	374.09	387.63	
нагрузка потребителей	335.71	251.68	
нагрузка в шунтах	0.00	0.00	
потери в связях - QL	38.39	135.95	
установленная нагрузка	335.71	251.68	
потери в линиях	20.45	39.05	
потери в шунтах линий	0.00	0.00	
генерация ЛЭП = QL	0.00	52.20	
потери в трансформаторах	17.94	149.10	
потери в шунтах трансф-ров	8.00	41.87	
баланс W(x): k-нормы	0.00	0.00	

a

результат: схема			
количество подсистем	1		
отключено связей	0		
погашено узлов	0		
суммарные: (мвт)/(мгвар)	активные	реактивные	
выработка на станциях	364.75	347.11	
нагрузка потребителей	335.71	251.87	
нагрузка в шунтах	0.00	0.00	
потери в связях - QL	29.04	95.24	
установленная нагрузка	335.71	251.87	
потери в линиях	13.53	28.84	
потери в шунтах линий	0.00	0.00	
генерация ЛЭП = QL	0.00	54.06	
потери в трансформаторах	15.52	120.46	
потери в шунтах трансф-ров	8.73	45.50	
баланс W(x): k-нормы	0.00	0.00	

b

Fig. 2. General mode calculation results obtained in the PRRES program:
a – prior to the implementation of measures; b – following the implementation of measures

Рис. 2. Общие результаты расчета режима в программе «ПРЕСС»: а – результаты до осуществления мероприятий; б – результаты после осуществления мероприятий

Power values of the compensating device
Значения мощностей компенсирующих устройств

Node Name	Node Number	Voltages before CD installation, kV	Power CD Mvar	Voltage after installation of CD, kV
Haqiqat	3042	25.24	2.02	35
Youngiyerr	3047	24.78	4.56	35
Momohon	3050	26.94	7.1	35
Navruz	3053	25.11	5.32	35
3057	3057	25.67	7.23	35
Mashrab	3081	24.67	5.34	35
Turakurgon-2	3088	23.55	7.83	35
30911	30911	23.01	6.13	35
Gova	3101	24.82	0.9	35
Galaba	3104	22.55	11.01	35
Marmar	3108	28.26	1.14	35
Tergachi	3111	27.88	5.08	35
3115	3115	28.06	4.16	35
Sum Q_{CD}	–	–	67.82	–

having a total power of 67.82 Mvar were installed (see table).

The installation cost of a 1 Mvar CD comes to \$50,000 [16]. The average cost of electricity per 1 kW/h amounts to \$0.37 in the republic.

Thus, the CD cost comes to $67.82 \cdot 50,000 = \$3,391,000$.

The amount of electrical energy saved due to the reduced active energy losses is determined as follows:

$$\Delta W = \Delta P \cdot \frac{T}{k},$$

where ΔP – reduction in active power losses in the grid, MW; T – number of hours per year, h; k – average load factor.

$$\Delta W = 9.35 \cdot \frac{8760}{2.19} = 37,400 \frac{MW}{h}.$$

Thus, the cost of electricity saved over one year amounts to

$$\Delta C = 37,400 \cdot 37 = \$1,383,800.$$

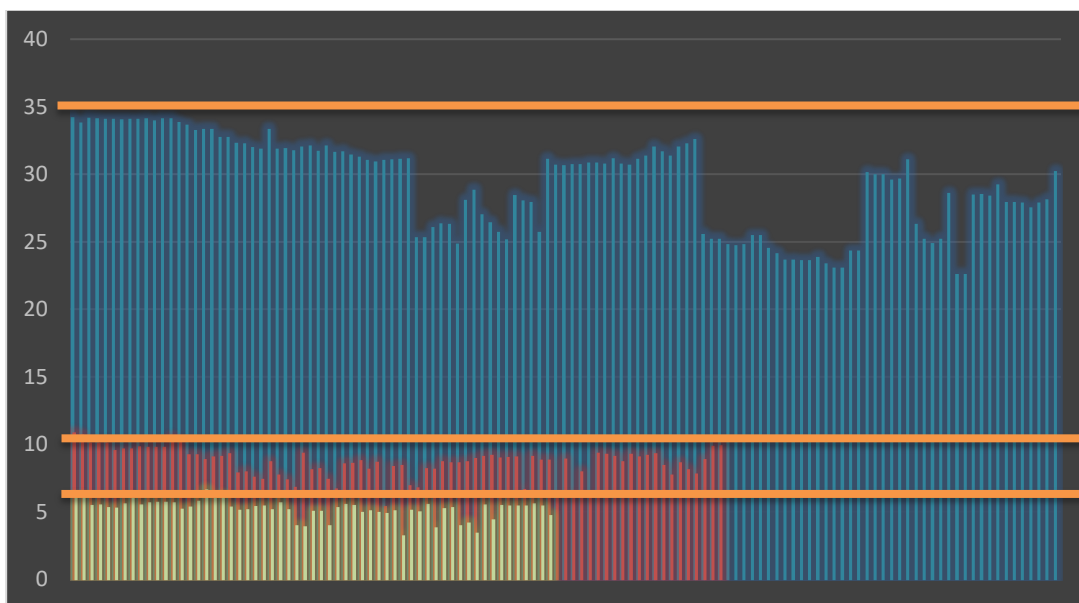

a

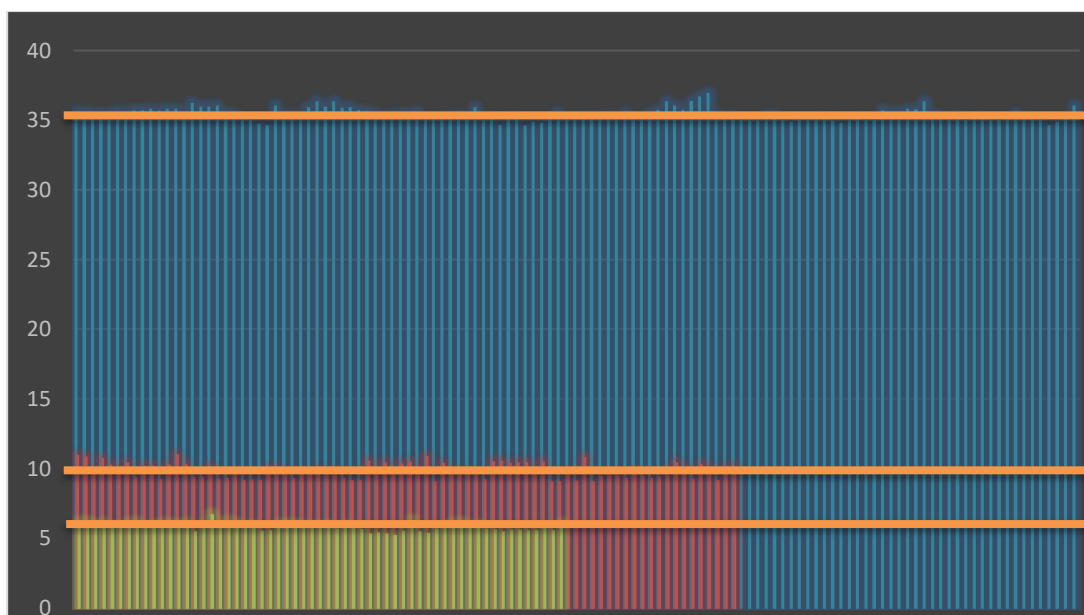

b

Fig. 3. Graph representing the 35-10-6 kV voltage level: a – prior to the implementation of measures; b – following the implementation of measures
Рис. 3. График уровня напряжений 35-10-6 кВ: а – результаты до осуществления мероприятий; б – результаты после осуществления мероприятий

It takes about three years for the measures aimed at reducing active energy losses and normalizing voltage deviations to be paid back, i.e.:

$$3,391,000 \div 1,383,800 = 2.45 \approx 3 \text{ years.}$$

CONCLUSION

The conducted studies indicate that the

electrical grids of the Namangan Region in Uzbekistan require the implementation of the proposed measures: reactive power compensation and transformer ratio adjustment to reduce electrical energy losses and maintain voltage at a given level.

The proposed measures allow electrical energy losses to be reduced by 24% while saving \$1.38 million a year and normalizing

the voltage level in 6–10 kV consumers.
In case Uzbekistan grid companies take an

interest in this work, it is possible to organize cooperation.

References

1. Zaslouov S. V., Kalinkina M. A. Calculation of power and electricity technical losses in 0.38-10 kV distribution networks. *Energetik*. 2002;7:21-22. (In Russ.).
2. Dolinger S. Yu., Goryunov V. N., Plankov A. A., Sidorov O. A. Schemes of active filtering of current in four-wire three-phase network for improving power quality. *Omskii nauchnyi vestnik = Omsk Scientific Bulletin*. 2011;3:214-217. (In Russ.).
3. Sikorski T., Rezmer J. Distributed generation and its impact on power quality in low voltage distribution networks. *Power Quality Issues in Distributed Generation*. 2015;1(6):34-41. <https://doi.org/10.15199/48.2015.06.05>.
4. Sudnova V. V. *Quality of electrical energy*. Moscow: Energoservis; 2000, 80. (In Russ.).
5. Voinov S. L., Gamm A. 3., Golub I. I., Zhezhenko I. V., Zhelezko Yu. S., Nejman V. V., et al. *Rationing of electrical power quality indicators and their optimization*. Glivice – Irkutsk; 1988, 249 p. (In Russ.).
6. Goryunov V. N., Osipov D. S., Lyutarevich A. G. Calculation of power losses depending on higher harmonics. *Nauchnye problemy transporta Sibiri i Dal'nego Vostoka*. 2009;2:268-273. (In Russ.).
7. Bushuev V. V., Lizalek N. N., Novikov N. L. *Dynamic properties of power systems*. Moscow: Energoatomizdat; 1995, 320 p. (In Russ.).
8. Vittal V., McCalley J. D., Anderson P. M., Fouad A. A. *Power system control and stability*. 3rd Edition. Hoboken: Wiley-IEEE Press; 2002, 832 p.
9. Sadykova F. M. Analysis of electrical energy losses and their reduction methods in the Makhachkala power grids. Rationing of electrical energy technological losses. *Sistemnye tekhnologii*. 2014;12:90-95.
10. Andrianova L. P., Valeev R. I. Problems of ensuring electrical power quality and methods to reduce losses in 0.4 kV rural distribution electrical networks. *Mezhdunarodnyj nauchnyj zhurnal "Innovacionnaya Nauka"*. 2018;03:20-24. (In Russ.).
11. Chen Yu, Xu Zhao, Ostergaard J. Frequency analysis for planned islanding operation in the Danish distribution system – Bornholm. In: *43rd International Universities Power Engineering Conference*. 1–4 September 2008, Padova. Padova: IEEE; 2008. <https://doi.org/10.1109/UPEC.2008.4651467>.
12. Nourollah S., Charehpetian G. B. Coordinated load shedding strategy to restore voltage and frequency of microgrid to secure region. *IEEE Transactions on Smart Grid*. 2019;10(4):4360-4368. <https://doi.org/10.1109/TSG.2018.2857840>.
13. Vadi S., Padmanaban S., Bayindir R., Blaabjerg F., Mihet-Popa L. A review on optimization and control methods used to provide transient stability in microgrids. *Energies*. 2019;12(18). <https://doi.org/10.3390/en12183582>.
14. Merkuriev G. V., Shargin Yu. M. *Power system stability*. In 2 vol., vol. 2. St. Petersburg: Nonstate private educational institution of additional professional education Center for Training Energy Personnel; 2008, 376 p. (In Russ.).
15. Khan M. T. A review of electrical energy management techniques: supply and consumer side (industries). *Journal of Energy in Southern Africa*. 2009;20(3):312-336. <https://doi.org/10.17159/2413-3051/2009/v20i3a3304>.
16. Belyaev N. A., Egorov A. E., Korovkin N. V., Chudnyj V. S. Consideration of capacity adequacy criterion in optimizing the prospective structure of electric power system. *Nadezhnost' i bezopasnost' energetiki = Safety and Reliability of Power Industry*. 2020;13(1):11-16. <https://doi.org/10.24223/1999-5555-2020-13-1-11-16>.
17. Tsumura T., Takeda T., Hirose K. A tool for calculating reliability of power supply for information and communication technology systems. In: *INTELEC 2008 - 2008 IEEE 30th International Telecommunications Energy Conference*. 14–18 September 2008, San Diego. San Diego: IEEE; 2008. <https://doi.org/10.1109/INTLEC.2008.4664080>.
18. Volodarskii V. A. Estimation of distribution function parameters with incompleteness of information on gradual failures of electrical equipment. *Promyshlennaya energetika*. 2019;8:8-13. (In Russ.).
19. Amuzade A. S., Tankovich T. I. Analysis of reliability indicators of power supply systems. In: N. V. Kuz'mina, V. A. Kozlova, N. M. Romanchenko (eds.). *Resursosberegayushchie tekhnologii sel'skogo hozyajstva = Agricultural resource-saving technologies*. Krasnoyarsk: Krasnoyarsk State Agrarian University; 2019, p. 61-66. (In Russ.).
20. Khristinich R. M., Lukovenko A. S. Power transformers reliability and mode of operation in the ultimate load prediction. *Sovremennye tekhnologii. Sistemnyi analiz. Modelirovanie = Modern technologies. System analysis. Modeling*. 2015;2:130-136. (In Russ.).
21. Karagodin V. V., Revyakov B. A., Rybakov D. V. An approach to determination of power supply system reliability. *Trudy voenno-kosmicheskoy akademii imeni A. F. Mozhajskogo = Proceedings of the Mozhaisky Military Space Academy*. Saint-Petersburg: the Mozhaisky Military Space Academy. 2018, p. 121-125. (In Russ.).
22. Malafeev A., Iuldasheva A. The structural reliability and adequacy assessment of the industrial electric power systems with local power plants. *Machines. Technologies. Materials*. 2018;12(4):165-168.
23. Ayuev B. I., Davydov V. V., Erokhin P. M. Fast and reliable method of searching power system marginal states. *IEEE Transactions on Power Systems*. 2016;31(6):4525-4533. <https://doi.org/10.1109/TPWRS.2016.2538299>.

Список источников

1. Заслонов С. В., Калинкина М. А. Расчет технических потерь мощности и электроэнергии в распределительных сетях 0,38-10 кВ // Энергетик. 2002. № 7. С. 21–22.
2. Долингер С. Ю., Горюнов В. Н., Планков А. А., Сидоров О. А. Схематические решения активной фильтрации кривой тока в четырехпроводной трехфазной сети для обеспечения качества электрической энергии // Омский научный вестник. 2011. № 3. С. 214–217.
3. Sikorski T., Rezmer J. Distributed generation and its impact on power quality in low-voltage distribution networks // Power Quality Issues in Distributed Generation. 2015. Vol. 1. Iss. 6. P. 34–41. <https://doi.org/10.15199/48.2015.06.05>.
4. Суднова В. В. Качество электрической энергии. М.: Изд-во ЗАО «Энергосервис», 2000. 80 с.
5. Воинов С. Л., Гамм А. З., Голуб И. И., Жежеленко И. В., Железко Ю. С., Нейман В. В. [и др.]. Нормирование показателей качества электроэнергии и их оптимизация: монография. Гливице – Иркутск, 1988. 249 с.
6. Горюнов В. Н., Осипов Д. С., Лютаревич А. Г. Расчет потерь мощности от влияния высших гармоник // Научные проблемы транспорта Сибири и Дальнего Востока. 2009. № 2. С. 268–273.
7. Бушуев В. В., Лизалек Н. Н., Новиков Н. Л. Динамические свойства энергосистем. М.: Изд-во «Энергоатомиздат», 1995. 320 с.
8. Vittal V., McCalley J. D., Anderson P. M., Fouad A. A. Power system control and stability. 3rd Edition. Hoboken: Wiley-IEEE Press, 2002. 832 p.
9. Садыкова Ф. М. Анализ потерь электрической энергии и пути их снижения в городских электрических сетях г. Махачкалы. Нормирование технологических потерь электрической энергии // Системные технологии. 2014. № 12. С. 90–95.
10. Андрианова Л. П., Валеев Р. И. Проблемы обеспечения качества электроэнергии и пути снижения потерь в сельских распределительных электрических сетях 0,4 кВ // Международный научный журнал «Инновационная Наука». 2018. № 03. С. 20–24.
11. Chen Yu, Xu Zhao, Ostergaard J. Frequency analysis for planned islanding operation in the Danish distribution system – Bornholm // Proceedings of 43rd International Universities Power Engineering Conference (Padova, 1–4 September 2008). Padova: IEEE; 2008. <https://doi.org/10.1109/UPEC.2008.4651467>.
12. Nourollah S., Charehpetian G. B. Coordinated Load Shedding Strategy to Restore Voltage and Frequency of Microgrid to Secure Region // IEEE Transactions on Smart Grid. 2019. Vol. 10. Iss. 4. P. 4360–4368. <https://doi.org/10.1109/TSG.2018.2857840>.
13. Vadi S., Padmanaban S., Bayindir R., Blaabjerg F., Mihet-Popa L. A Review on Optimization and Control Methods Used to Provide Transient Stability in Microgrids // Energies. 2019. Vol. 12. Iss. 18. <https://doi.org/10.3390/en12183582>.
14. Меркурьев Г. В., Шаргин Ю. М. Устойчивость энергосистем. В 2-х т., т. 2. СПб.: НОУ «Центр подготовки кадров энергетики», 2008. 376 с.
15. Khan M. T. A review of electrical energy management techniques: supply and consumer side (industries) // Journal of Energy in Southern Africa. 2009. Vol. 20. No. 3. P. 312–336. <https://doi.org/10.17159/2413-3051/2009/v20i3a3304>.
16. Беляев Н. А., Егоров А. Е., Коровкин Н. В., Чудный В. С. Учет критерия балансовой надежности при оптимизации перспективной структуры энергосистемы // Надежность и безопасность энергетики. 2020. Т. 13. № 1. С. 11–16. <https://doi.org/10.24223/1999-5555-2020-13-1-11-16>.
17. Tsumura T., Takeda T., Hirose K. A tool for calculating reliability of power supply for information and communication technology systems // INTELEC 2008 - 2008 IEEE 30th International Telecommunications Energy Conference (San Diego, 14–18 September 2008). San Diego: IEEE, 2008. <https://doi.org/10.1109/INTLEC.2008.4664080>.
18. Володарский В. А. Оценка параметров функций распределения при неполноте информации о постепенных отказах электрооборудования // Промышленная энергетика. 2019. № 8. С. 8–13.
19. Амузаде А. С., Танкович Т. И. Анализ показателей надежности систем электроснабжения // Ресурсосберегающие технологии сельского хозяйства: сб. науч. ст. Вып. 11 / под ред. Н. В. Кузьмина, В. А. Козлова, Н. М. Романченко. Красноярск: Изд-во КрасГАУ, 2019. С. 61–66.
20. Христинич Р. М., Луковенко А. С. Прогнозирование надежности и режимов работы тяговых трансформаторов в условиях предельной нагрузки // Современные технологии. Системный анализ. Моделирование. 2015. № 2. С. 130–136.
21. Карагодин В. В., Ревяков Б. А., Рыбаков Д. В. Подход к определению надежности систем электроснабжения // Труды военно-космической академии имени А.Ф. Можайского Вып. 663. СПб.: Изд-во Военно-космической акад. им. А. Ф. Можайского, 2018. С. 121–125.
22. Malafeev A., Iuldasheva A. The structural reliability and adequacy assessment of the industrial electric power systems with local power plants // Machines. Technologies. Materials. 2018. Vol. 12. Issue 4. P. 165–168.
23. Ayuev B. I., Davydov V. V., Erokhin P. M. Fast and reliable method of searching power system marginal states // IEEE Transactions on Power Systems. 2016. Vol. 31. No. 6. P. 4525–4533. <https://doi.org/10.1109/TPWRS.2016.2538299>.

INFORMATION ABOUT THE AUTHORS

Stepan G. Tiguntsev,

Cand. Sci. (Eng.), Associate Professor,
Associate Professor of the Department of
Electric Power Plants, Networks and Systems,
Irkutsk National Research Technical University,
83 Lermontov St., Irkutsk 664074, Russia

Sardor B. Akhmedov,

Postgraduate Student,
Melentiev Energy Systems Institute SB RAS,
130 Lermontov St., Irkutsk 664033, Russia

Said B. Usmonov,

Master's Degree Student,
Irkutsk National Research Technical University,
83 Lermontov St., Irkutsk 664074, Russia

Contribution of the authors

The authors contributed equally to this article.

Conflict of interests

The authors declare no conflicts of interests.

The final manuscript has been read and approved by all the co-authors.

Information about the article

The article was submitted 31.05.2022; approved after reviewing 21.07.2022; accepted for publication 19.09.2022.

ИНФОРМАЦИЯ ОБ АВТОРАХ

Тигунцев Степан Георгиевич,

кандидат технических наук, доцент,
доцент кафедры «Электрические станции,
системы и сети»,
Иркутский национальный исследовательский
технический университет,
664074, г. Иркутск, ул. Лермонтова, 83, Россия

Ахмедов Сардор Бахтиярович,

аспирант,
Институт систем энергетики им.
Л.А. Мелентьева СО РАН,
664033, г. Иркутск, ул. Лермонтова, 130, Россия

Усмонов Саид Бахтиярович,

магистрант,
Иркутский национальный исследовательский
технический университет,
664074, г. Иркутск, ул. Лермонтова, 83, Россия

Вклад авторов

Все авторы сделали эквивалентный вклад в подготовку публикации.

Конфликт интересов

Авторы заявляют об отсутствии конфликта интересов.

Все авторы прочитали и одобрили окончательный вариант рукописи.

Информация о статье

Статья поступила в редакцию 31.05.2022; одобрена после рецензирования 21.07.2022; принята к публикации 19.09.2022.